

# 3021A

Three Phase, 2-Leg Zero-Cross  
Command Signal: 0-5, 0-10Vdc  
or Potentiometer

## FEATURES

- Compact size
- Electrical isolation of command signal from load and line voltages.
- Controller accepts 0-5Vdc, 0-10Vdc or potentiometer commands.
- Zero-Cross Operation
- Diagnostic indicator
- Continuous operation at 55°C
- Distributive control
- Line voltage compensation

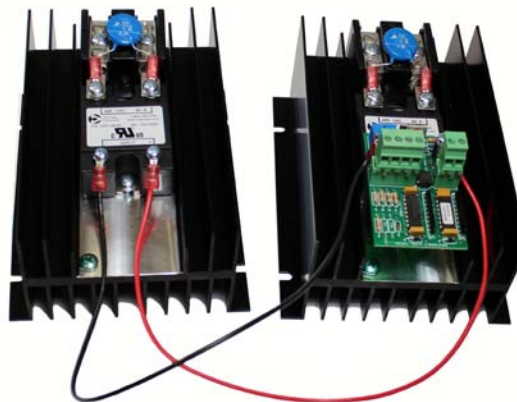

LISTED 3L32  
INDUSTRIAL  
CONTROL  
EQUIPMENT  
E136219



CERTIFIED  
BY UL TO  
CANADIAN  
NATIONAL  
STANDARDS



## APPLICATIONS

- Electric Ovens, Furnaces and Kilns
- Three-Phase Resistive Loads
- Environmental Chambers
- Contactor Replacement
- Platen heaters
- Extruders

## DESCRIPTION

The model 3021A is a two-leg zero-cross SCR power controller that linearly controls, proportional to 0-5Vdc or 0-10Vdc or potentiometer command signal, the power applied to a 3 phase electrical load. The controller is available with current ratings from 10 to 70 Amps and voltage ratings from 120 to 575 Vac.

The controller consists of a master and a slave assembly. Each assembly consists of a heatsink and an SCR (Silicon Controlled Rectifier) module containing two SCRs configured to operate as a zero-cross AC switch. The SCR module also provides electrical isolation between the line and load voltage and the heatsink and the input command to the SCR module.

An electronic circuit on the master assembly controls the ON/OFF switching of the SCR module causing the load power to be directly proportional to the command signal. The fast ON/OFF zero-cross switching improves heater life and provides superior performance over that achieved by relays, contactors or other solid state time proportional controls.

The 3021A has proven to be an economical and very compact power control solution for industrial applications requiring high reliability and long life.

## ADVANTAGES

- Size of enclosure and panel space are reduced.
- Eliminates potential ground loops. Provides safe operation with inexpensive, non-isolated process controllers.
- Load power can be linearly controlled from 0 to 100% by either a potentiometer or by a process controller.
- Power is switched ON and Off when voltage is zero.
- Light emitting diode (LED) provides visual indication of controller operation.
- No de-rating required below 55°C.
- Provides highest cycle to cycle resolution of the power level required.
- Maintains the load power constant independent of line voltage changes.

## BENEFITS

- Valuable space is saved, enclosure costs are reduced.
- A less costly, more reliable means to achieve good process control.
- Provides flexibility and readily allows the use of auto/manual and run/idle control circuits.
- Zero-Cross operation improves reliability and reduces RFI.
- Provides an easily understood means to troubleshoot by inexperienced personnel.
- Improves reliability and provides long trouble-free life.
- Infinite resolution of load power and fast response provides superior process control.
- Line voltage variations do not affect load power, provides better process control.

## THEORY OF OPERATION

The model 3021A is a zero-cross distributive controller. Zero-cross implies that load power can be turned ON or OFF only at the beginning or end of each electrical half cycle when the instantaneous value of the applied voltage is zero.

Distributive control provides rapid ON-OFF cycling of the load power and combines various cycling rates

to obtain the desired load power with infinite resolution. At 50% power the 3021A controller is ON for 3 electrical cycles and OFF for 3 electrical cycles. At lower power levels load power is applied for 3 cycles and the number of OFF cycles is increased.

At power levels above 50% power is removed for 3 cycles and the number of ON cycles is increased. For example, at 75% power the controller is on for 9 cycles and off for 3 cycles. At 60% power the controller is ON for 4 cycles, OFF for 3 cycles, then ON for 5 cycles followed by 3 OFF cycles, providing 9 ON cycles out of a total of 15 cycles. This rapid switching makes it possible to control relatively fast responding heaters and improves the life of heaters because the element temperature remains relatively constant.

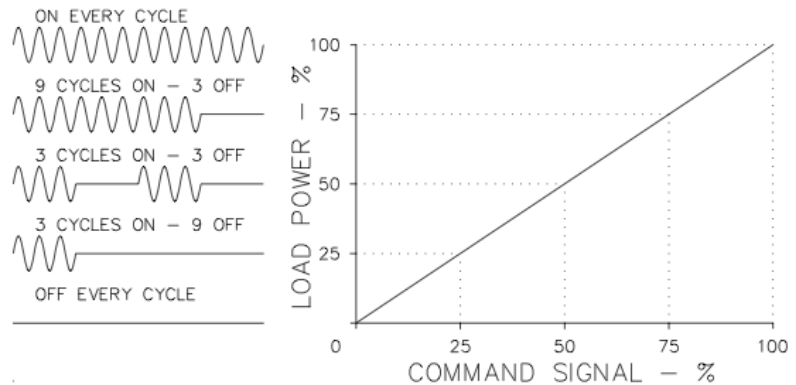

# SPECIFICATIONS

<b>Control Mode</b>	3-phase, 2-leg, zero-cross - distributive control Delta & 3 wire WYE loads.							
<b>Command Signal</b>	0-5Vdc or 0-10Vdc, 4/20mA or potentiometer (1K to 20K.)							
<b>Input Impedance</b>	0-5Vdc input = 100K, / 0-10Vdc input & potentiometer = 200K.							
<b>Control Range</b>	0 to 100% of line voltage - 2 Volts.							
<b>Linearity</b>	Average load power is linear within 1% of the command signal.							
<b>Zero and Span Adjustment</b>	User adjustable over range of $\pm 20\%$ of span.							
<b>Isolation</b>	Dielectric strength input/line & load voltage/heatsink 4000V <sub>RMS</sub> . Insulation resistance input/line & load voltage/heatsink $10^{10}$ ohms. Maximum capacitance input to output 8pf.							
<b>Cooling</b>	Convection.							
<b>Mounting</b>	Must be mounted on vertical surface with fins vertical. Units may be mounted adjacent to each other. (Heatsink is electrically isolated.)							
<b>Line Voltage</b>	120, 240, 480 or 575Vac +10%, -15% 50/60 Hertz.							
<b>Diagnostic Indicator</b>	An LED turns ON whenever the solid state relay is ON. Feature provides a quick and safe means to check controller operation.							
<b>Physical</b>	Weight; 10 thru 40 Amp 4lbs, 70 Amp 12 lbs. Dimensions: refer to installation drawing.							
<b>Approximate Shipping Weight and Box Size</b>	70A            18-14-12" Box Size							
<b>Environment</b>	Operating:    0° to 55°C (32 to 131°F). Storage:     -40° to 80°C (-40 to 176°F). Humidity:    0 to 100%, non-condensing.							
<b>dv/dt &amp; Transient Voltage</b>	500 volts/usec minimum. A dv/dt snubber and a metal oxide varistor (MOV) are provided to protect against high frequency transients (dv/dt) and voltage spikes.							
<b>Dissipation</b>	1.5 watts per amp of controlled current.							
<b>Recommended Fusing</b>	Special semiconductor fuses are not required. It is recommended that the controller and load be protected with fast acting class "T" fuses such as Bussmann type JJS or JJN fuses. Control Concepts maintains an inventory of fuses and fuse holders for your convenience.							
<b>Current Capacity</b>				<b>KW</b>				
<b>Continuous RMS rating Amps</b>	<b>RMS 1 second</b>	<b>Peak 1 cycle (Non-Repetitive)</b>	<b>I<sup>2</sup>t rating</b>	<b>120 Vac</b>	<b>240 Vac</b>	<b>277 Vac</b>	<b>480 Vac</b>	<b>575 Vac</b>
10	22	140	81	2.08	4.16	4.80	8.31	9.96
20	40	250	260	4.16	8.31	9.60	16.63	19.92
30	80	625	1620	6.24	12.47	14.39	24.94	29.88
40	150	1000	4150	8.31	16.63	19.19	33.26	39.84
70	150	1000	4150	14.55	29.10	33.58	58.26	69.72

# DIMENSIONS

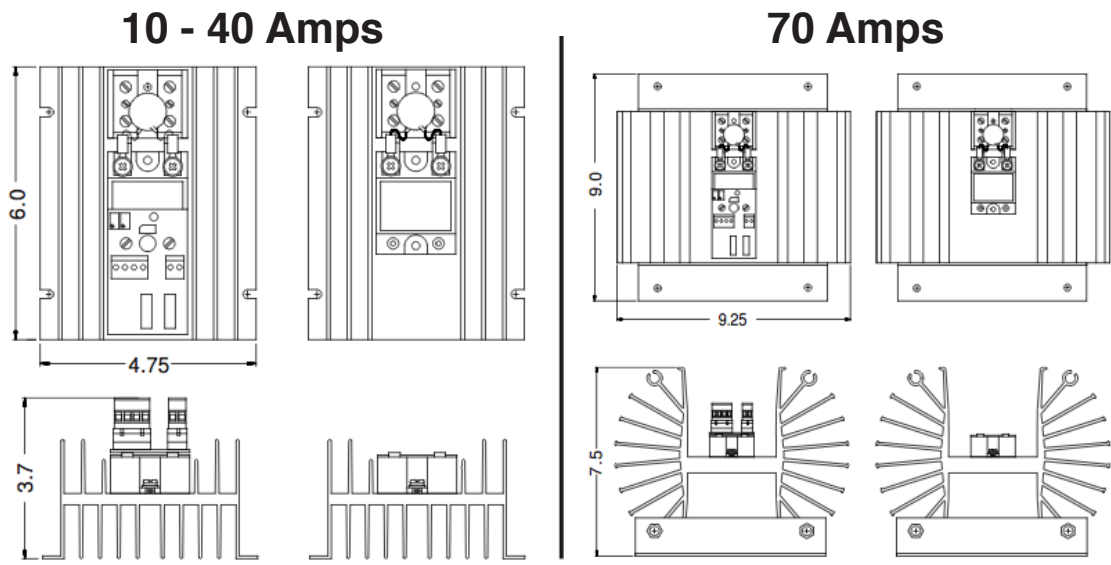

THE TRANSFORMER SUPPLIED WITH THE MODEL 3021A VARIES IN SIZE DEPENDING UPON THE LINE VOLTAGE

# ORDERING INFO

## 3021A - XX - XX - XX

**Specify Voltage:**  
 12 = 120V    24 = 240V  
 48 = 480V    57 = 575V

**Specify Current:**  
 10, 20, 30, 40 or 70 Amps

**Specify Command Signal:**  
 0/5 Volts    0/10 Volts,  
 4/20mA    Potentiometer

# PLEASE NOTE

The model 3021A controls two of the three legs of a Wye or Delta load; the third leg is connected directly to the third phase line.

Control Concepts' model 3321A controls all three legs of a Wye or Delta load.

Controlling all three legs would be necessary if the load is a four-wire Wye with the junction wire grounded.

If one of the SCR's in a three leg controller would short, control of power to the load would be maintained.

If one of the SCR's in a two-leg controller would short, full power would be applied to one leg, and a minimum of half power would be applied to each of the other two legs.

# CONTACT/ORDERING INFORMATION

TEL: (952) 474-6200 | (800) 765-2799  
 FAX: (952) 474-6070 | www.cciipower.com  
 8077 Century Blvd, Chanhassen, MN 55317, USA

