

3337

Three Phase Three-Leg, Zero-Cross SCR Power Controller

FEATURES

- Electrical isolation of command signal from load and line voltages.
- Linear power with respect to command signal plus line voltage compensation.
- SCR Protection
- Compact size
- Phase Rotation
- Sync-guard™
- Trans-Guard™
- Diagnostic Indicator
- Very fast cycle rate
- Underwriters Laboratories Listed
- Fused Line Input
- Thermostat
- Fused Control Circuit



LISTED 3L32
INDUSTRIAL
CONTROL
EQUIPMENT
E136219



CERTIFIED
BY UL TO
CANADIAN
NATIONAL
STANDARDS

APPLICATIONS

- Resistive Loads
- Electric Ovens, Furnaces, and Kilns
- Environmental Chambers

DESCRIPTION

The model 3337 is a three-leg, three-phase, zero-cross SCR power controller. The model 3337 provides control of electrical power to resistive loads by means of silicon controlled rectifiers. Control of power is linear with respect to a command signal. The command signal is electrically isolated from the line and load voltage.

The model 3337 controller features a compact design and a single plug-in circuit card for ease of operation. All three line leads of the 200 to 320 Amp frames are fused. It is recommended that fuses be installed ahead of the line inputs for the 500, 600 and 750 Amp frames.

The unit accepts 4/20mA, 0-5Vdc, 0-10Vdc or potentiometer command signals. The model 3337 controller has shorted SCR detection.

ADVANTAGES

Eliminates potential ground loops. Provides safe operation with inexpensive, non-isolated process controllers.

Provides a stable control loop because load power is proportional to command signal and is not affected by line voltage variations.

High Voltage Peak Rating with dV/dT Snubber and MOVs.

Tests for shorted SCR every 5 seconds.

Size of enclosure and panel space are reduced.

The 3337 is not sensitive to phase rotation.

Reduces synchronous operation of multiple SCR controllers to obtain a smoother power demand.

Eliminates DC load currents and therefore transformer overheating due to saturation from induced DC primary voltages.

Light emitting diode (LED) provides visual indication of controller operation.

Rapid on-off operation provides a nearly continuous flow of power.

Nationally Recognized Testing Facility.

Fuses in 3 legs on line side. See page 4 (85 to 425 Amps only.)

Senses the heatsink temperature. Protects control circuit and its transformer.

BENEFITS

A less costly, more reliable means to achieve good process control.

Product quality remains constant.

SCR less likely to fail.

Snubber and MOV to protect against high frequency Transients and voltage spikes.

A relay with form "C" contacts rated at 120 Vac @ 5A changes state when a Shorted SCR is detected.

Valuable space is saved, enclosure costs are reduced.

Exchange of line leads is unnecessary.

Cooler operation of supply transformers, circuit breakers, etc., greatly reduces the possibility of voltage variations resulting multiple controllers cycling on and off at the same time.

Eliminates supply transformer problems caused by SCR controller operation. Increased transformer life.

Provides an easily understood means to troubleshoot by inexperienced personnel.

Reduces down time.

Provides uniform heating, longer heater life and allows use with fast responding loads.

Tested for your safety.

Type "T" fuses protect SCRs and load.

Prevents overheating by shutting the unit off.

Removes power from control circuit on detection of high temperature.

SPECIFICATIONS

Control Mode(s)	Three-phase, Two-leg, zero-cross control.	
Command Signal	Range 4-20mA 0-5Vdc 0-10Vdc 1K - 20K pot	Input Resistance 249 ohms 500K 200K 200K
Power Circuit	Inverse parallel Silicon Controlled Rectifiers (SCR's).	
Operating Voltage	208 / 240 / 380 / 415 / 480 / 575 (+10%, -20%), 50/60 Hertz. Consult factory for other voltages.	
Ambient Temperature	Operating: 0° to 55°C Storage: -40° to 80°C	
Humidity	0 to 90%, non-condensing.	
SCR Protection	1400 Volt Peak dV/dT 200 Volts/second.	
Diagnostic Indicator	The frequency of operation of the LED is proportional to the command signal. It is "ON" when power is applied to the load.	
Heat Dissipation	1.5 watts per leg per Amp of load current. For example: The 500 Amp frame at full load would produce 2250 watts heat dissipation.	
Isolation	Isolation between power circuit, command signal and ground is greater than 2500 volts RMS.	

Linearity and Voltage Compensation	Load power is linear with respect to the command signal. Variations in load power resulting from supply voltage variations are reduced by an average voltage feedforward technique.
Control Range	0 to 99.5% of supply voltage.
Transient Protection	dV/dT snubber circuits and MOV's are used to protect against high frequency transients (dV/dT) and voltage spikes.
Zero and Span	Multiturn potentiometers provide adjustment of zero and span. (Range approx. ±20%)
Mounting	Although controllers with fans may be mounted in any position, it is recommended that these controllers be mounted on a vertical panel with the fans on the bottom.
Physical	Weight: 240 - 425 Amp = ~60 lbs. 500 - 750 Amp = ~95 lbs. Dimensions: Refer to installation dwg on Page 3
Approximate Shipping Weight and Box Size	500-1000A 110 Lbs* 30-30-16" Box Size

* ships on a pallet, weight doesn't include pallet

TYPICAL FRAME WIRING & CONNECTIONS

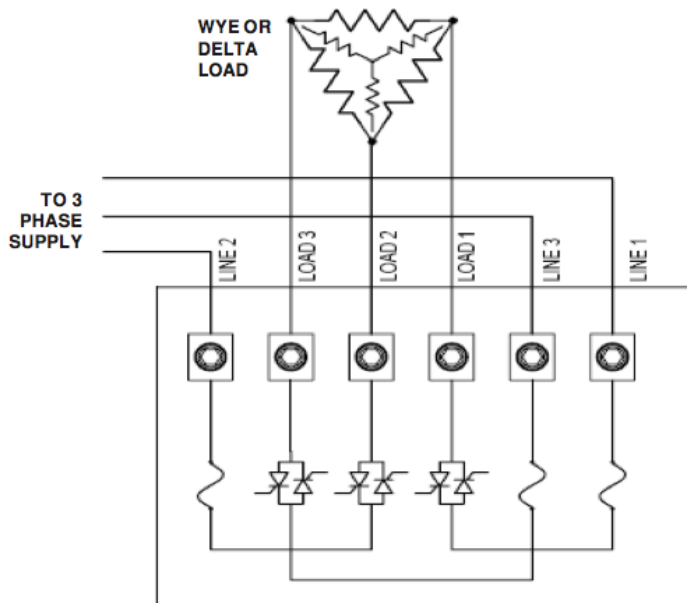

Due to internal space limitations, Units rated 500 Amps or more do not have internal line fuses. It is recommended that the user install fuses in the power lines ahead of the controller. Size the fuses at about 125% of the maximum current load.

INSTALLATION DRAWINGS

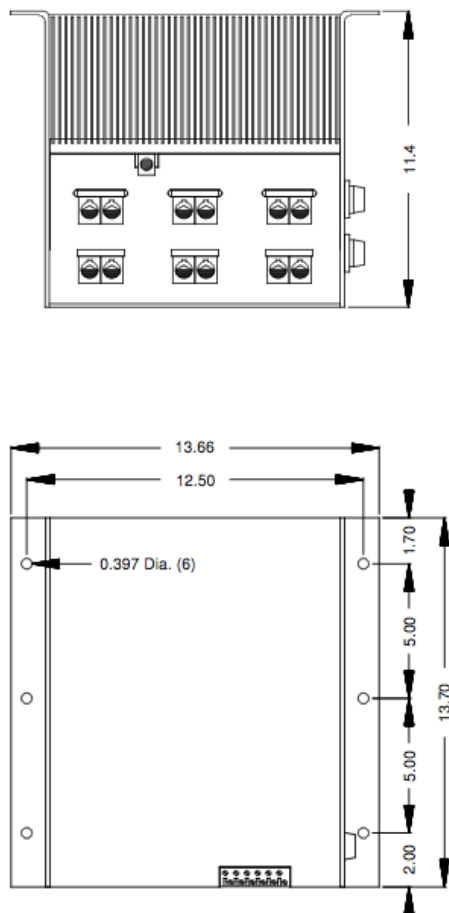

240, 295, 370 & 425 AMP

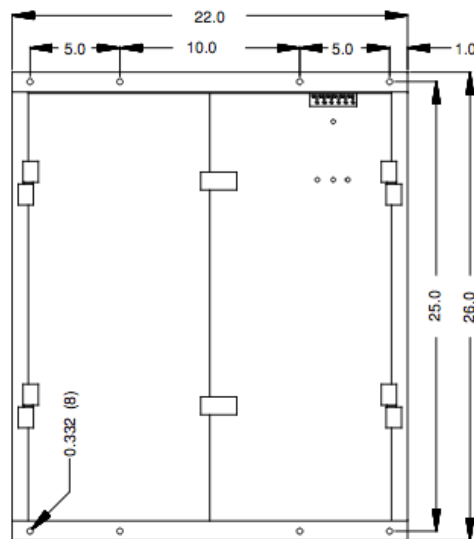
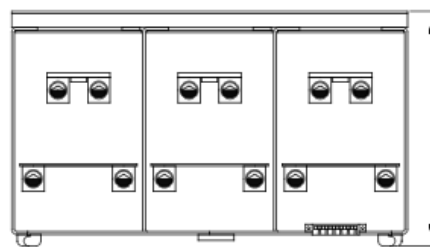

500, 600 & 750 AMP

Although controllers with fans may be mounted in any position, it is recommended that these controllers be mounted on a vertical panel with the fans on the bottom.

ORDERING INFO

3337 - (XXX)V - (XXX)A - (XXXXXX)

Voltage: _____
208, 240, 380, 415, 480, or 575.

Current: _____
200, 240, 280, 320, 500, 600, 750A

Command: _____
0/5V, 0/10V, 4/20 mA, or Potentiometer

CONTACT/ORDERING INFORMATION

TEL: (952) 474-6200 | (800) 765-2799
 FAX: (952) 474-6070 | www.cci-power.com
 8077 Century Blvd, Chanhassen, MN 55317, USA

